

1500Vdc System Turnkey Solution

Central Inverter & Transformer Turnkey Solution for 1500V System SPI3125K-B-HUD/T



Product Features

Highly integrated - turnkey solution

- Integrated with outdoor central PV inverter for 1500V System
- Equipped with inverter & transformer system (10kV~35kV optional)
- Integrated intelligent transformer measurement and control device, one-stop solar farm communication solution

Lean intelligence - full monitoring collection

- Integrated multi - function transformer measurement and control device, intelligent operation management
- Unified external communication interface, rapid deployment and debugging
- Intelligent I-V and fault wave recording, quick failure analysis

Efficient and stable - reliable

- IP55 design, high environmental adaptability
- Optimized inverter and step up unit, higher system efficiency

Lower investment, higher income

- Integrated connection of inverter and transformer, reduce system cost
- Reserve energy storage interface for future PV+ESS projects
- Support night SVG function, reduce construction cost

Function Diagram

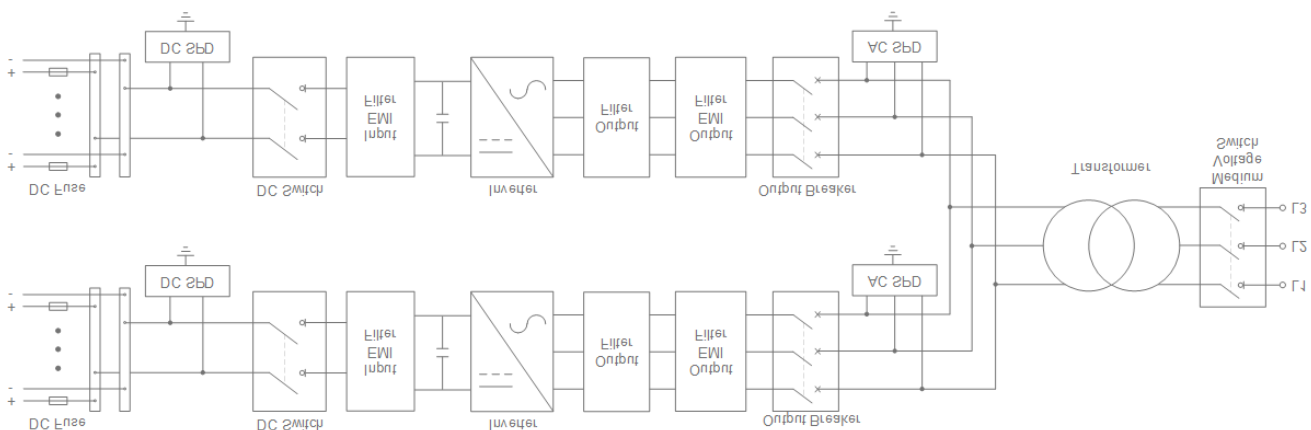

Technical Specification

Items	SPI3125K-B-HUD/T
DC Input	
Max. PV input voltage	1500Vdc
Max. PV input current	3992A
No. of PV input strings	16~24 optional
No. of MPPTs	2 (1 optional)
MPPT voltage range	875~1500Vdc
Starting voltage	915Vdc
MPPT efficiency	>99.9%
AC Output	
Rated AC output power	3125kW
Max. output power	3438kVA
Rated grid voltage	10~35kV
Rated grid frequency	50Hz/60Hz
Power factor	>0.99 (at rated power)
PF adjustable range	0.8 leading~0.8 lagging
THDi	<3% (at rated power)
Inverter efficiency	
Max. efficiency	99.02%
European efficiency	98.55%
Transformer	
Transformer type	oil-immersed transformer
Rated power	3125kVA
Voltage transformation ratio	3438kVA
Isolation mode	Dy11/Yd11
Protection	
LVRT function	Yes
Fault wave record diagnosis	Yes
Online upgrade	Yes
Night SVG function	Yes
Anti-PID function	Optional
Transformer measuring and controlling device	Yes
General	
Dimensions (W×H×D)	5500×2650×2438mm
Weight	13T
IP grade	IP55
Transformer cooling type	ONAN
Inverter cooling type	Intelligent forced air cooling
Altitude	3000m (>3000m optional)
Operating temperature range	-35°C~60°C
Relative humidity	0~100%
Display	LCD
Communication	Ethernet, RS485

- Specifications are subject to change without prior notice.